

**PROJECT: Demo geothermal pilot for application in residential  
buildings nZEB (GEOPILOT)  
PN-III-P2-2.1-PED-2019-2881**

**Summary of stage 2**

Stage 2 of the GEOPILOT project took place between January and December 2021 and was mainly represented by the purchase of equipment for the experimental stand, while performing numerical simulations and preliminary experimental studies necessary to optimize the equipment chosen in the experimental stand.

The financing stage was opened by UEFISCDI in April, which delayed the start of procurement procedures. During all this time, the project team carried out the preliminary numerical and experimental studies necessary to choose the components of the installation. The equipment that was purchased for the construction of the geothermal installation, as well as for its location, are the following:

- The container representing the technical room for the independent positioning of the proposed installation outside the building,
- LED display for data transmission and display in order to raise awareness of the impact of the heat pump system on energy consumption (energy and environmental information).
- Ecoforest ground-water heat pump
- Ecoforest air-water heat pump
- Heat exchanger with plates for passive cooling
- Pipelines for horizontal route of geothermal probes
- Elastomer insulation for installation pipes
- Buffer 200 liters
- Boiler capacity 300 liters trivalent for domestic hot water preparation
- Expansion vessels
- Temperature sensors
- 3-way valves with modulating servomotor
- Other accessories: fittings, circulation pumps, fittings, safety valves, etc. After all the necessary equipment was purchased and delivered to the location, the actual realization of the technical room and the start of the assembly followed:
- The optimal location / position of the container was identified, representing the technical room dedicated to the installation specific to the geothermal pilot, annexed to the existing building studied.
- The foundation was built and the container was installed
- The installations / equipment have been downloaded
- The installations were positioned in the technical room and the assembly started.

After completing these stages, the hydraulic connections and the commissioning of the installation will be made, as well as the start of the experimental campaigns related to the project.

**Activities carried out between January and December 2021**

The work plan of the GEOPILOT project for this stage is structured as follows:

Work Package 2 (WP2). Building Energy Management System (BEMS) design

A2.2. Purchase of necessary materials

A2.3. Implementation of BEMS (2 publications at national / international conferences); partially completed in 2020 and continued since January 2021.

Work Package 3 (WP3). Optimization and coupling of the geothermal system with other energy sources

A 3.1. Energy measurement for demo-site 1 (EFDEN House)

A 3.2. Energy measurement for demo-site 2 (Dubai Solar Decathlon House)

A 3.3. Optimization of the two systems and stage ratio

Work Package 4 (WP4). Dissemination of project results

A4.1. Dissemination of project results - ISI / BDI listed articles and a scientific progress report.

### **Equipment ordered for the GEOPILOT project**

The equipment that was ordered for the GEOPILOT project is divided into two categories:

1. Main equipment for the realization of the geothermal installation,
2. Secondary equipment for the construction of the technical room, respectively automation and display.

The existing installation of the EFdeN solar house has as a source an air-to-water heat pump that supplies a buffer used for cooling, a buffer used for heating and a boiler used for domestic hot water preparation. The boiler and the heating buffer are also powered by a system with two solar panels with vacuum tubes. The indoor installation of the building has a heating / cooling system with radiant panels powered by thermal fluid, positioned in the ceiling and walls of the house. Also, the thermal fluid circulates through the battery after the heat recuperator used to treat the freshly introduced air.

To complete the existing installation, two 3-way valves with servomotor will be provided, and the proposed geothermal installation will represent an independent heating system for the indoor installation. The equipment that was purchased to complete the geothermal installation is as listed above.



Figure 1. Heat pump equipment used for the proposed system

The proposed ground-to-water heat pump will operate in a hybrid system, being completed by an air-to-water heat pump. The heat pump system sends the heat fluid to a buffer for heat storage and efficient operation of the heat pump and a trivalent boiler for domestic hot water preparation with input from the heat pump, solar panels or even an electric heater as back-up.

The role of the plate heat exchanger is to ensure the operation of the heat pump in passive cooling mode.

The system proposed in the GEOPILLOT project is completely independent of the original building analyzed, which connects to the existing indoor installation through two 3-way valves located before the general distributor-collector that transmits the heating fluid to the radiant heating / cooling system located in the ceiling and walls of the building.

An experimental Ecoforest ecoGEO + 1-6PRO & AU hybrid heat pump will be used in the experimental stand, which can operate in both ground-water and air-water mode, in bivalent mode, thus ensuring maximum efficiency of the entire system. The heat pump can provide the functions of heating, cooling and domestic hot water preparation and uses R290 as refrigerant, with a very low GWP value (GWP = 0), with a low impact on the environment. The heat pump has a power ranging from 1kW to 6kW, COP (B0 / W35) up to 4.9, EER (B35 / W7) up to 5.2 and can supply heat with a temperature of up to 70°C on the installation flow.

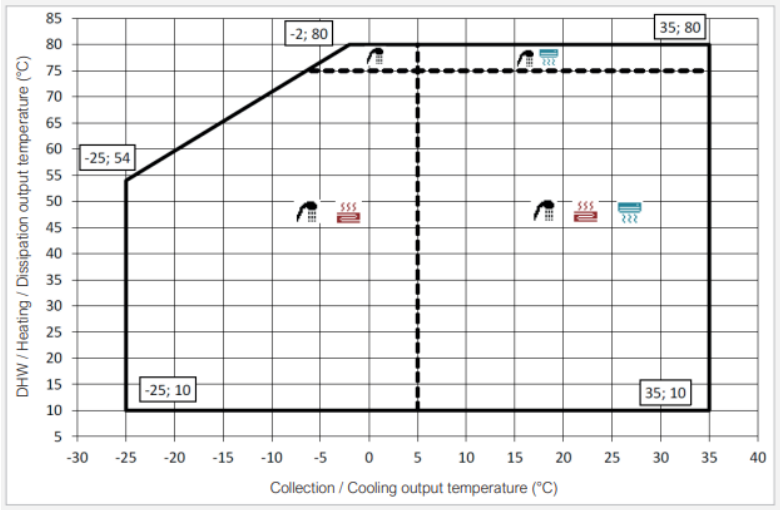

Figure 2. Functioning limits of the heat pump

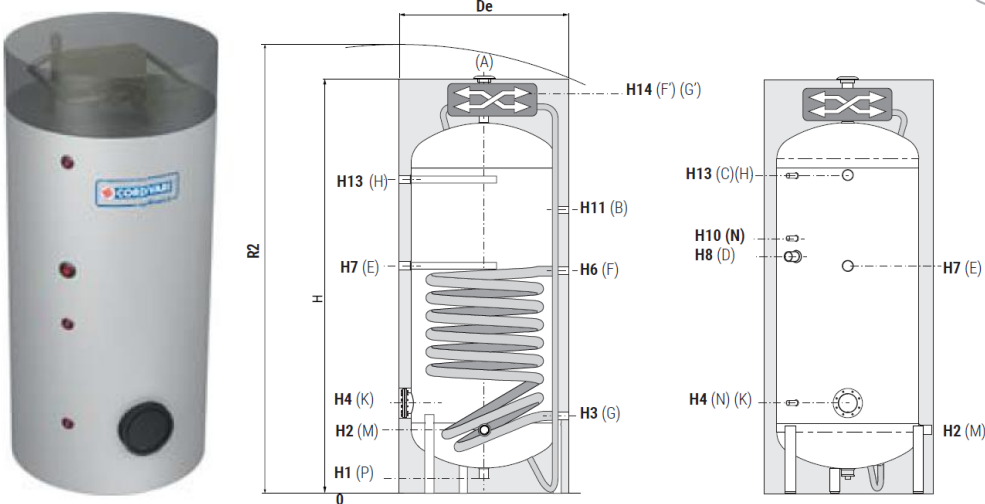

Figure 3. Trivalent boiler for the heat pump system

The boiler used in the installation is a trivalent one for the preparation of domestic hot water, with enlarged coil (input from the heat pump, from the solar panels and from the back-up electrical resistance).

To ensure the passive cooling mode, a plate heat exchanger was dimensioned and purchased:

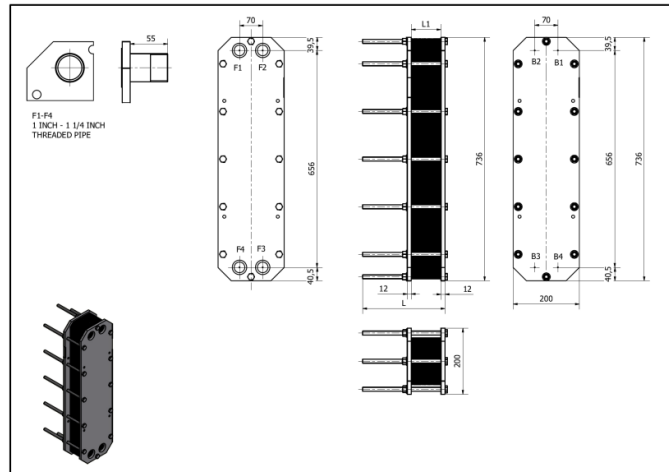

Figure 4. Plate heat exchanger for passive cooling mode

The secondary equipment for the realization of the technical room, purchased for the project are:

- o The container representing the technical room for the independent positioning of the proposed installation outside the building
- o LED display for data transmission and display in order to raise awareness of the impact of the heat pump system on energy consumption (energy and environmental information). The LED display will be positioned in a visible place and will play a role in raising the awareness of those who will visit the experimental stand on the impact of the implementation of renewable energy sources in energy efficient buildings.



Figure 5. Programmable LED display and its programming possibility



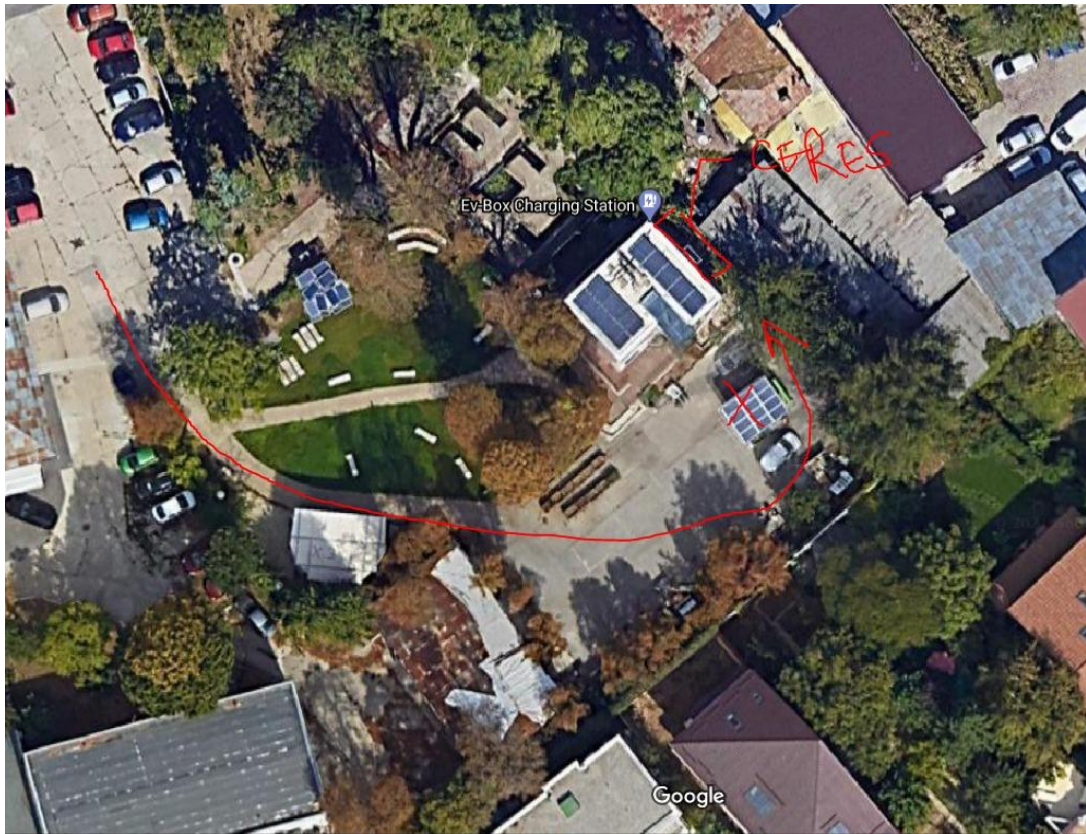

Figure 6. Position of the container for the technical room of the GSHP system

a



b



Figure 7. Concrete foundation for the container (a – before, and b – after)





Figure 8. Unloading of the container



Figure 9. Unloading the pieces of equipment for the technical room (a) and the final positioning of the container on the concrete foundation slab (b)



Figure 10. Preliminary positioning of the equipment in the container (technical room located close to the existing building)